

# FFDXRA & FFDXRA-MA

REVERSE FLOW FAN FILTER UNITS  
MOTOR & ELECTRONICS ACCESSIBLE

READ COMPLETELY AND SAVE THESE INSTRUCTIONS FOR FUTURE REFERENCE

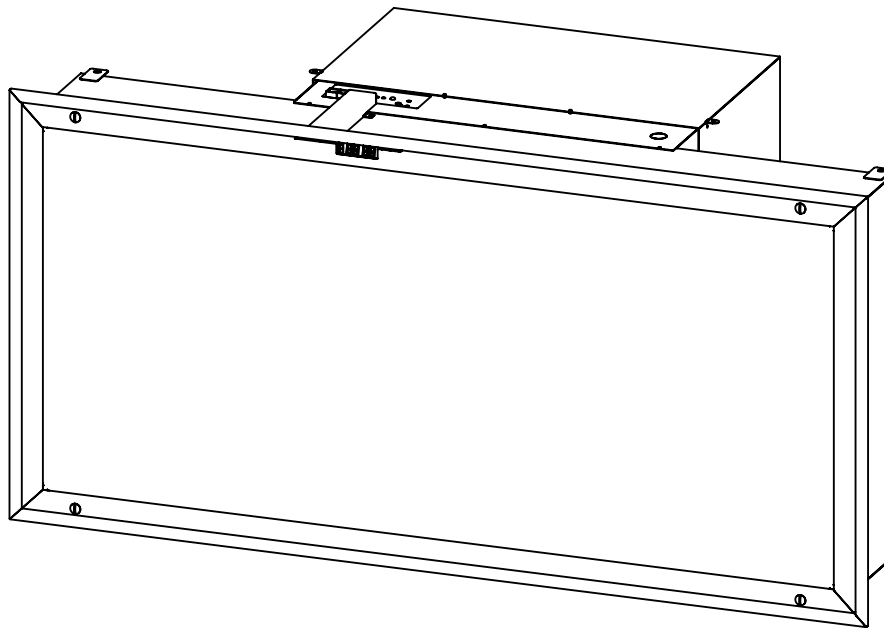

**FFDXRA**

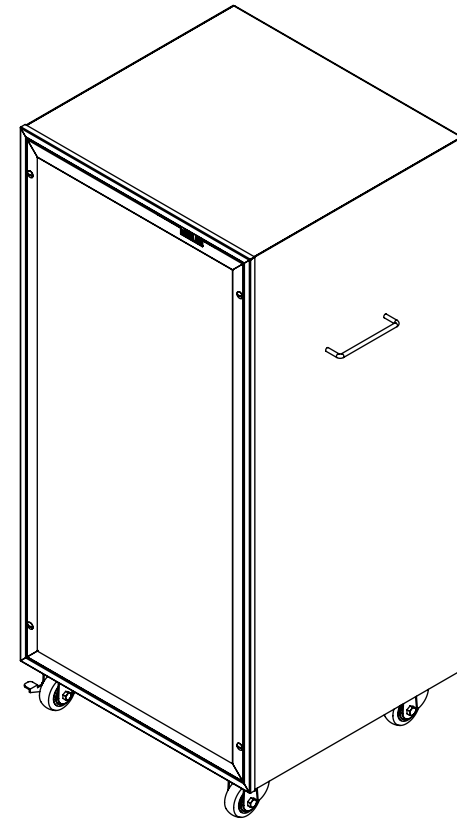

**FFDXRA-MC**



DRAWN BRS	MATERIAL	JOB NAME	TAG	QTY	REV # E
CHKD	FINISH	ENGINEER	DRAWING NAME		SHT 1/28
APRVD	SIZE	CONTRACTOR			SCL 1:10
					DO NOT SCALE

# FFDXRA & FFDXRA-MC

## REVERSE FLOW FAN FILTER UNIT

### MOTOR & ELECTRONICS ACCESSIBLE

#### Critical operation conditions of the Fan Filter Unit

- DO NOT TOUCH the HEPA filter media. Damage to filter media may void the filter warranty. The screen is to protect against accidental contact with the filter. Never place objects on the filter. Always transport or lift the filter by its frame.
- Prior to powering the unit, verify that it is wired to the correct power supply. The rating plate label located on the electrical box shows the electrical data.
- For replacement parts refer to the model number and serial number on the rating plate label located on the electrical box.

#### Replacement Part numbers

FFU-RP11 - 48 x 24 x 3.5" High-Flow HEPA filter  
 FFU-RP12 - 36 x 24 x 3.5" High Flow HEPA filter  
 FFU-RP13- 24 x 24 x 3.5" High Flow HEPA filter  
 FFU-RP21 - Variable speed motorized impellor (120 VAC)  
 FFU-RP22 -Variable speed motorized impellor (208, 240, 277 VAC)  
 FFU-RP31 - Main control board  
 FFU-RP32 - Airflow measure and display system  
 FFU-RP33 - Face control/display board (board only)  
 FFU-RP34 - 120 -- 24 VAC transformer  
 FFU-RP35 - 208/240 -- 24 VAC transformer  
 FFU-RP36 - 277 -- 24 VAC transformer  
 FFU-RP37 - Network power control circuit board  
 FFU-RP38 - PAO challenge system  
 FFU-RP39 - Safety shut-off switch

FPH-RP40 - Resetable fuse (8A up to 240 VAC)  
 FPH-RP41 - Fuse holder with fuse (5A @ 277 VAC)  
 FPH-RP42 - Cartridge fuse (5A @ 277 VAC)

WHEN ORDERING REPLACEMENT PARTS, PLEASE INCLUDE UNIT MODEL & SERIAL NUMBER AND PO # IF AVAILABLE.



DRAWN BRS	MATERIAL	JOB NAME	TAG	QTY	REV # E
CHKD	FINISH	ENGINEER	DRAWING NAME INSTALL AND OPERATION		SHT 2/28
APRVD	SIZE	CONTRACTOR			SCL 1:10
					DO NOT SCALE

# FFDXRA & FFDXRA-MC

REVERSE FLOW FAN FILTER UNIT  
MOTOR & ELECTRONICS ACCESSIBLE

READ COMPLETELY AND SAVE THESE INSTRUCTIONS

**WARNING - TO REDUCE THE RISK OF FIRE, ELECTRIC SHOCK, OR INJURY TO PERSONS,  
ALLOW ONLY QUALIFIED TECHNICIANS TO INSTALL AND SERVICE THE UNIT. ALL  
PERSONS SHOULD OBSERVE THE FOLLOWING:**

- a) Use this unit only in a manner intended by the manufacturer. If you have questions, contact the manufacturer.
- b) Before servicing or cleaning unit, switch power off at the servicepanel and lock-out the service in accordance with OSHA (LOTO) practices and procedures to prevent power from being accidentally switched on avoiding accidental electric shock and injury. When the service disconnecting means cannot be locked, securely fasten a prominent warning device, such as a tag, to the service panel.
- Installation work and electrical wiring must be completed by qualified personnel in accordance with all applicable codes and standards, to include fire-rated constructions.
  - When cutting or drilling into walls and ceilings, be careful not to damage electrical wiring and other hidden utilities.
  - If this unit is to be installed within close proximity to water, mark the unit in accordance with applicable codes and standards.
  - This unit is to be used only as intended by the manufacturer. If you have any questions regarding the use, installation, or operation of this unit, contact the manufacturer:



DRAWN BRS	MATERIAL	JOB NAME	TAG	QTY	REV # E
CHKD	FINISH	ENGINEER	DRAWING NAME INSTALL AND OPERATION		SHT 3/28
APRVD	SIZE	CONTRACTOR			SCL 1:10
					DO NOT SCALE

# FFDXRA & FFDXRA-MC

## REVERSE FLOW FAN FILTER UNIT

### MOTOR & ELECTRONICS ACCESSIBLE

## INSTALLATION CHECKLIST

This is to provide a general overview of what steps should be taken to achieve a successful installation of the fan filter unit. These steps should be performed in the order listed. For more detail see applicable section in this instruction manual. Read the entire manual before beginning installation.

- Prepare the installation site with appropriate power, data cabling, support structure, and openings as needed.
- Unbox and inspect the fan filter unit.
- Install the fan unit into the ceiling. Support its weight from structure above.
- Connect ductwork to fan unit (if applicable).
- Seal the fan filter unit to the ceiling using gasketing and caulking.
- If the unit is to be ducted, set upstream air device to produce 0.0" W.C. static pressure at the fan unit inlet.  
Use dampers if necessary if installing multiple fan units on the same duct line.
- Connect main power wiring.
- Connect control wiring (if applicable).
- Run the unit and/or upstream air device to flush out construction debris.
- Install the pre-filter (if applicable).
- Install the HEPA/ULPA filter.
- Turn unit on and adjust airflow to design CFM.
- Turn on the upstream airflow device.
- Leak test the fan unit and filter per local codes and building procedures.
- Install the perforated face screen.
- Verify airflow with a flow hood.



DRAWN BRS	MATERIAL	JOB NAME	TAG	QTY	REV # E
CHKD	FINISH	ENGINEER	DRAWING NAME INSTALL AND OPERATION		SHT 4/28
APRVD	SIZE	CONTRACTOR			SCL 1:10
					DO NOT SCALE

## Installation

The terminal unit is fully assembled from the factory with the exception of the HEPA filter. Filter is shipped in a separate box.

Step 1 -- Carefully remove the unit from the shipping carton and inspect for damage that may have occurred during shipping. If shipping damage is found, do not install. Call the supplier to report damage.

Step 2 -- Wipe down unit to remove shipping dust and debris.

Step 3 -- Raise unit into position and secure using the hanger tabs. Alternately it can be secured a framed opening through the frame if care is taken not to damage the knife edge and all penetrations are sealed. Any gasket should be a closed-cell material approved for the environmental conditions. Sealant used to seal the unit to the ceiling should be approved for the application and conditions.

Step 4 -- A qualified technician should connect the unit to the appropriate power supply per applicable codes and standards. Refer to the wiring diagrams included in these instructions. The electrical box will be accessible from the roomside.

FFDXRA-120 --- 120 VAC SUPPLY, 2.8 FLA  
 FFDXRA-208 --- 208 VAC SUPPLY, 2.6 FLA  
 FFDXRA-240 --- 240 VAC SUPPLY, 2.3 FLA  
 FFDXRA-277 --- 277 VAC SUPPLY, 1.9 FLA

Step 5 -- Blow out / clean entire duct system leading to unit to remove construction debris. This is especially important for motor accessible units as they do not have a pre-filter. Wash pre-filter if applicable per "Cleaning the Fan Filter Unit Pre-filter" on page 7.

Step 6 -- Install the HEPA filter per the "Removal and Replacement of the HEPA Filter with Gel Seal" section.

# FFDXRA & FFDXRA-MC

## REVERSE FLOW FAN FILTER UNIT MOTOR & ELECTRONICS ACCESSIBLE

**NOTE:** An additional disconnect should be added by others per applicable codes and regulations.

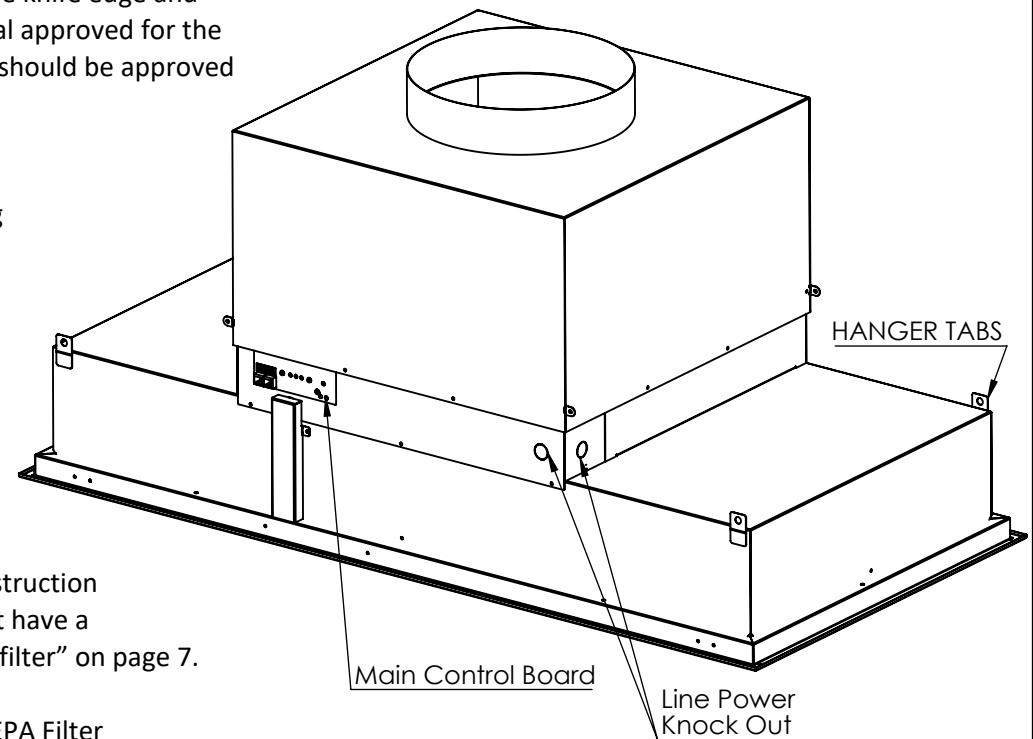

DRAWN BRS	MATERIAL	JOB NAME	TAG	QTY	REV # E
CHKD	FINISH	ENGINEER	DRAWING NAME INSTALL AND OPERATION		SHT 5/28
APRVD	SIZE	CONTRACTOR			SCL 1:10
					DO NOT SCALE

# FFDXRA & FFDXRA-MC

## REVERSE FLOW FAN FILTER UNIT MOTOR & ELECTRONICS ACCESSIBLE

### A NOTE ABOUT VAV BOXES AND DUCTED APPLICATIONS

In applications where the fan filter unit will be installed downstream of variable airflow devices such as VAV boxes, air valves, or variable air handlers, proper care in unit set-up needs to be taken.

**In these applications the unit should not be programed to run as constant airflow when ordered with the Airflow Sensor.**

Two variable controllers trying to reach their respective set point will continuously adjust. This will cause issues such as surging, starving, and eventual shut down of the fan filter unit. In these applications the unit should be placed into "open-loop" control by turning off the S1-1 dip switch (see pict below). This will no longer keep constant airflow automatically. It will also remove the dirty filter ramp-up feature and the HEPA-lert dirty filter indicator (if applicable) will be set as a static timer of 4400 hours (about 6 months). The set point will now be a percentage of motor speed instead of CFM but it will still display CFM during normal operation. The unit in this setting is still preferable to a PSC system due to the energy efficiency of an ECM versus a PSC motor and all control options are still applicable.

### CFM OUTPUT CALIBRATION

If ordered with the Airflow Sensor option tUse the "C" up and down arrows on the face control to calibrate the airflow sensor to match the balancer's flow hood to insure accurate airflow control. This calibration is best done as near to the operating point as possible. Recalibration may be required if the setpoint changes more than 25%.

### DUCTED APPLICATIONS

While the fan filter unit can handle some positive or negative static pressure, optimal performance and reliability will be achieved with an inlet static pressure of 0.0" WC or slightly negative.

In extreme cases the inlet conditions may not be able to be compensated for using the calibration adjustment. In these cases CFM controlled operation may have to be forfit and the unit run in open-loop mode.

To reach an accurate 0.0"WC inlet static, it is recommended that the primary air balancing of the duct system be done before installing the filter in the unit. When the duct is at optimal static, install the unit per these instructions and adjust the airflow to the design setting. Verify the airflow with an airflow hood.



DRAWN BRS	MATERIAL	JOB NAME	TAG	QTY	REV # E
CHKD	FINISH	ENGINEER	DRAWING NAME INSTALL AND OPERATION		SHT 6/28
APRVD	SIZE	CONTRACTOR			SCL 1:10
					DO NOT SCALE

# FFDXRA & FFDXRA-MC

REVERSE FLOW FAN FILTER UNIT  
MOTOR & ELECTRONICS ACCESSIBLE

## Reverse Flow Fan Filter Unit Pre-filter

The unit ships with a frameless disposable pre-filter between the face and the HEPA filter. It is not recommended that this filter be washed or re-used.

Replacement filters are available from Titus.

NOMINAL UNIT SIZE	PART NUMBER
48 x 24	U4A1
24 x 24	U4A2



DRAWN BRS	MATERIAL	JOB NAME	TAG	QTY	REV # E
CHKD	FINISH	ENGINEER	DRAWING NAME INSTALL AND OPERATION		SHT 7/28 SCL 1:12
APRVD	SIZE	CONTRACTOR			DO NOT SCALE

## Removal and Replacement of the HEPA Filter with Gel Seal

### WARNING!

Disconnect the unit from the electrical power source before attempting to service the unit.

### WARNING!

The HEPA filter may be protected by an expanded metal screen. The screen prevents accidental contact with the filter media.

It is not meant to allow handling of the filter by the media. Handle the filter ONLY by the frame.

NOTE: The manufacturer recommends two people to remove and install the HEPA filter in the unit.

Step 1 -- Using a flat screwdriver, release the face frame by rotating the four (4) fasteners a 1/4-turn counter clock-wise.

Unhook the safety cables from the filter clips. Set the frame aside.

Step 2 -- Turn the unit off with the switch located on the face of the unit (round, black button).

Step 3 -- Disconnect the unit at the power source or at the service panel in accordance with OSHA (LOTO) practices and procedures.

Step 4 -- USE TWO PEOPLE TO SUPPORT THE FILTER and rotate the swingarm filter clips off of the filter until clip is clear of the filter.

Step 4 ALT (if stud style filter clips) -- Using a 7/16" nut-driver, evenly loosen the nuts holding the filter retaining clips by working your way around the unit loosening the nuts a little at a time. To make installing the new filter easier, loosen the nuts until flush with the end of the threaded stud. USE TWO PEOPLE TO SUPPORT THE FILTER and rotate the filter clips toward the offset hole until clip is clear of the filter.

Step 5 -- Allow gravity to pull the filter away from the unit. If installing a new filter discard the filter in an appropriate manor.

Step 6 -- Unpack the new filter and inspect for shipping damage. If damage is found, do not install in unit; call the vendor for replacement arrangements.

Step 7 -- Using two people, raise the filter into place in between the filter guides (or threaded posts if stud style) assuring the seal edge is approximately in the center of the gel channel.

Step 8 -- While supporting the filter by its frame, rotate the filter clips so that the clips are supporting the frame and are at 90° to the frame. (ALT--Evenly tighten the nuts by working your way around the unit tightening the nuts a little at a time. Stop tightening when the aluminum filter frame contacts the stainless steel housing frame of the unit. **DO NOT OVER TIGHTEN**). Wait at least 30 minutes before performing any challenge testing to allow the gel to fully adhere to the unit.

Step 9 -- Inspect all gaskets and seals for integrity. Reconnect power and turn unit power on.

Step 10 -- Raise the face frame back into place, reattach the safety chains, and secure 1/4-turn fasteners.

# FFDXRA & FFDXRA-MC

## REVERSE FLOW FAN FILTER UNIT

### MOTOR & ELECTRONICS ACCESSIBLE

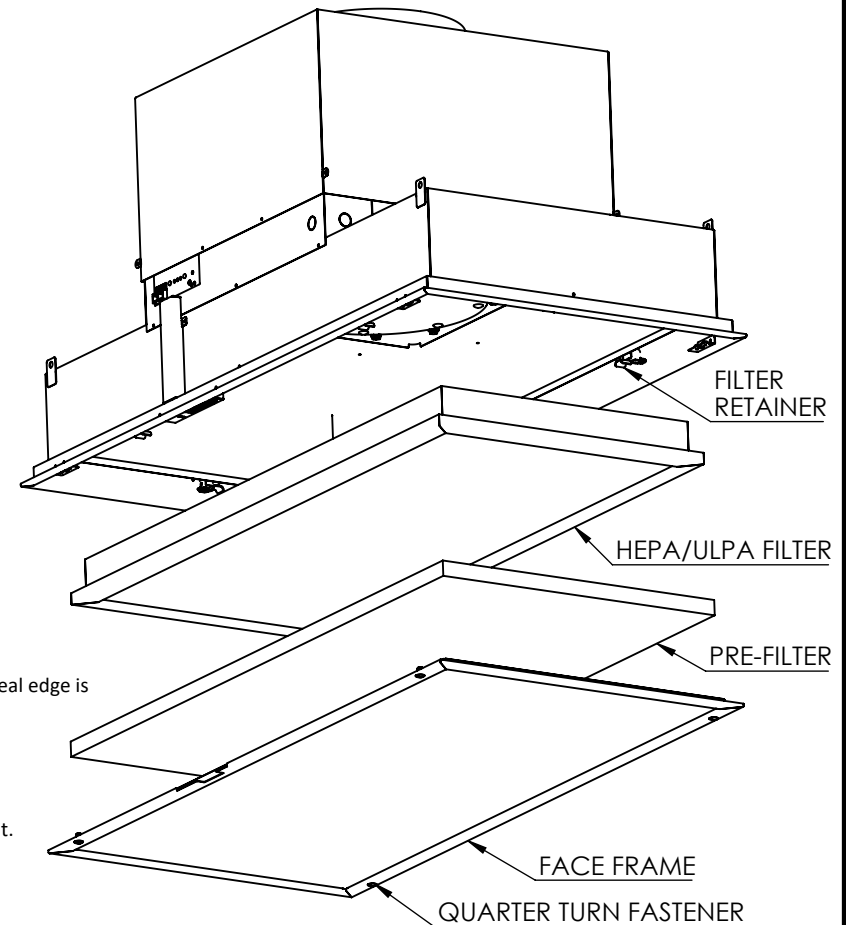

DRAWN BRS	MATERIAL	JOB NAME	TAG	QTY	REV # E
CHKD	FINISH	ENGINEER	DRAWING NAME INSTALL AND OPERATION		SHT 8/28
APRVD	SIZE	CONTRACTOR			SCL 1:12
					DO NOT SCALE



## Removal and Installation of the Variable Speed Motor (FFDXRA SHOWN)

### **WARNING!**

**Disconnect the unit from the electrical power source before attempting to service the unit.**

Step 1 -- Using a flat screwdriver, release the face frame by rotating the four (4) fasteners a 1/4-turn counter clock-wise. Unhook the safety cables from the filter clips. Set the frame aside.

Step 2 -- Turn the unit off with the black button located on the frame of the unit next to the display.

Step 3 -- Disconnect the unit at the power source or at the service panel in accordance with OSHA (LOTO) practices and procedures.

Step 4 -- Remove the HEPA filter and set aside. See sections 2 and 3 for instructions.

Step 5 -- If equipped with an Airflow Sensor make note of the plug into the sensor. Cut any zip-ties holding the wire to the sensor bracket. Unplug the wire and move out of the way.

Step 6 -- Support the weight of the fan assembly and use a 7/16" driver to remove the eight (8) motor mount plate screws.

Step 7 -- Carefully lower the motor assembly and disconnect the 3-pin power plug and the 4-pin data plug.

Step 8 -- Remove the assembly from the unit. Remove the nuts holding the motor brackets to the motor plate.

Step 9 -- Use a 4 mm hex driver to remove the four (4) screws holding the motor brackets to the motor.

Step 10 -- Reverse above steps to reassemble the motor/fan/ring assembly into the unit.

# FFDXRA & FFDXRA-MC

## REVERSE FLOW FAN FILTER UNIT

### MOTOR & ELECTRONICS ACCESSIBLE

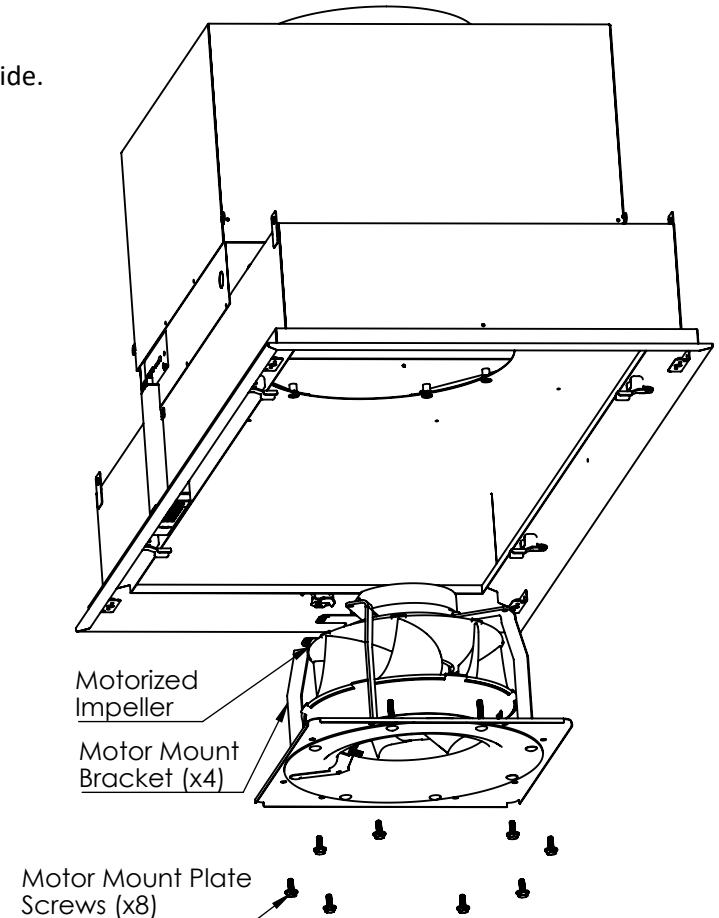

DRAWN BRS	MATERIAL	JOB NAME	TAG	QTY	REV # E
CHKD	FINISH	ENGINEER	DRAWING NAME INSTALL AND OPERATION		SHT 9/28
APRVD	SIZE	CONTRACTOR			SCL 1:10
					DO NOT SCALE

**Access to Electrical Components**  
**(FFDXRA SHOWN)**

**WARNING!**

Disconnect the unit from the electrical power source before attempting to service the unit.

- Turn the unit off with the switch located on the electrical box.
- Disconnect the unit at the power source or at the service panel in accordance with OSHA (LOTO) practices and procedures.

**FFDXRA & FFDXRA-MC**  
 REVERSE FLOW FAN FILTER UNIT  
 MOTOR & ELECTRONICS ACCESSIBLE

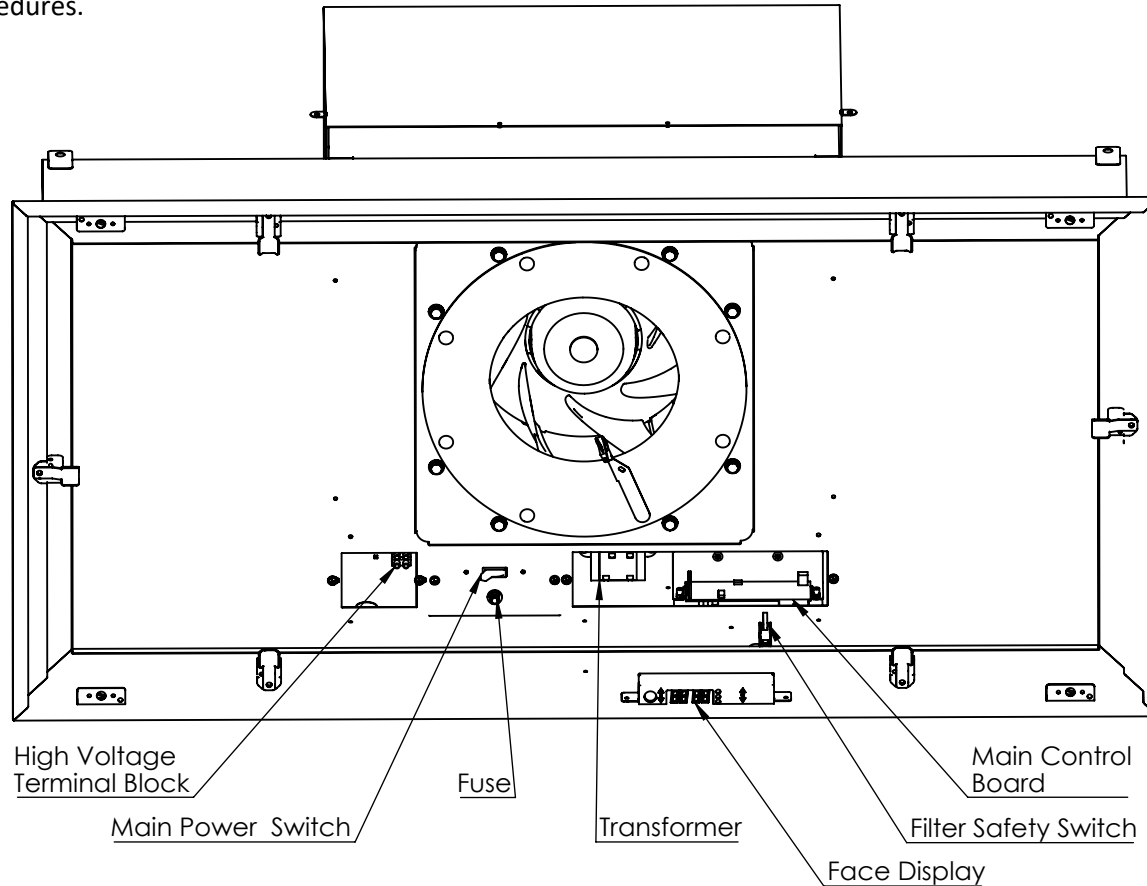

DRAWN BRS	MATERIAL	JOB NAME	TAG	QTY	REV # E
CHKD	FINISH	ENGINEER	DRAWING NAME INSTALL AND OPERATION		SHT 10/28
APRVD	SIZE	CONTRACTOR			SCL 1:8
					DO NOT SCALE

## Removal of Main Control Board

### WARNING!

Disconnect the unit from the electrical power source before attempting to service the unit.

# FFDXRA & FFDXRA-MC

## REVERSE FLOW FAN FILTER UNIT

### MOTOR & ELECTRONICS ACCESSIBLE

- Step 1 -- Access the unit's electrical box per instructions based on the model you have. (See pages 11-12)\_
- Step 2 -- Remove the two screws holding the control board face plate to the fan filter unit.
- Step 3 -- If applicable, disconnect the CAT5e cables from RJ45 jacks on the front of the board.
- Step 4-- Disconnect the motor (red 4-pin plug), the face control board (red 5-pin plug), and the safety switch (red 2-pin plug) from the main control board by pulling the plug straight out from the board.
- Step 5 -- Using a small blade screwdriver, disconnect power supply wires from the control board terminal block.
- Step 6 -- To install a new board, repeat above steps in reverse order.

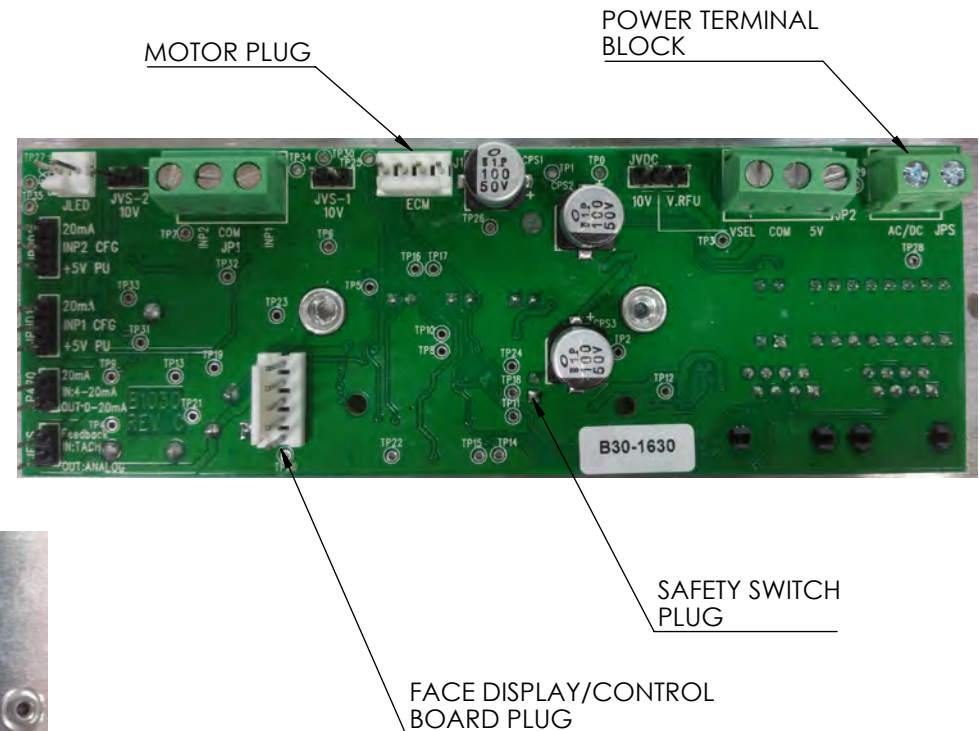
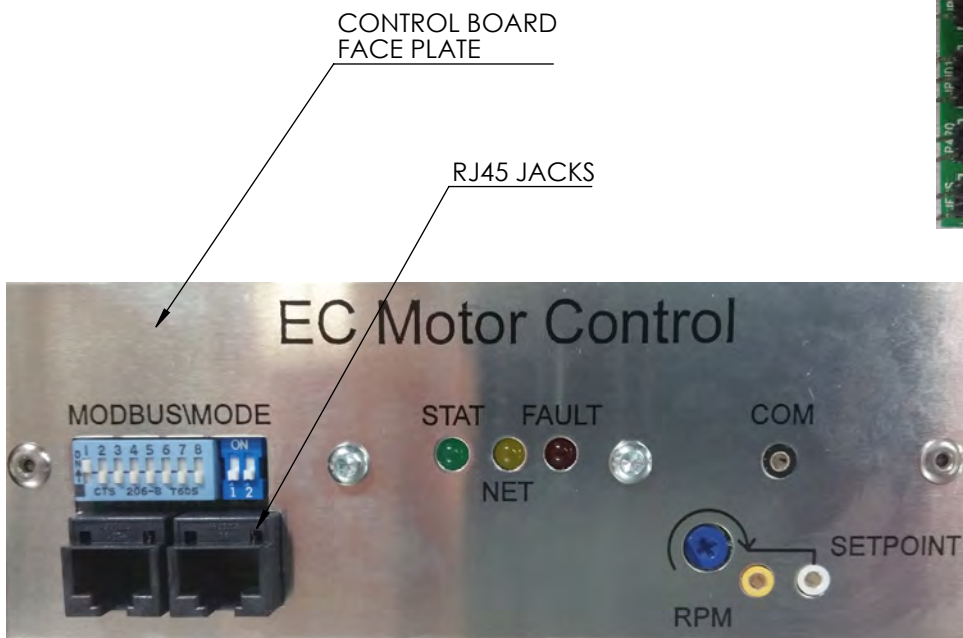

DRAWN BRS	MATERIAL	JOB NAME	TAG	QTY	REV # E
CHKD	FINISH	ENGINEER	DRAWING NAME INSTALL AND OPERATION		SHT 11/28
APRVD	SIZE	CONTRACTOR			SCL 1:10
					DO NOT SCALE

# FFDXRA & FFDXRA-MC

REVERSE FLOW FAN FILTER UNIT  
MOTOR & ELECTRONICS ACCESSIBLE

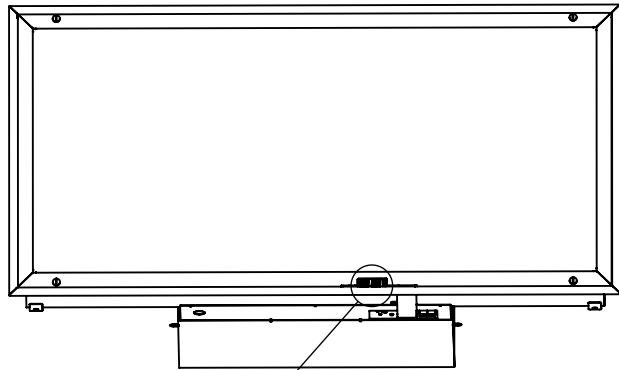

**FACE FRAME INSTALLED**

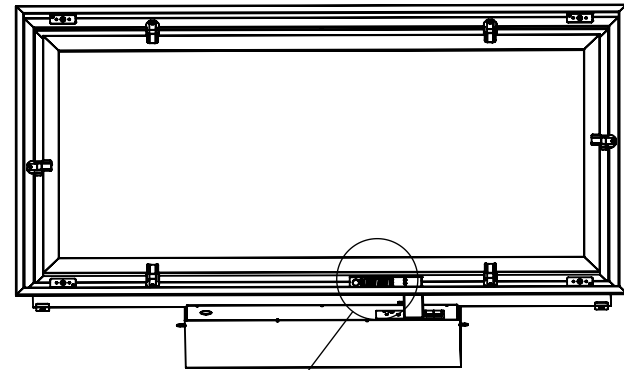

**FACE FRAME REMOVED**

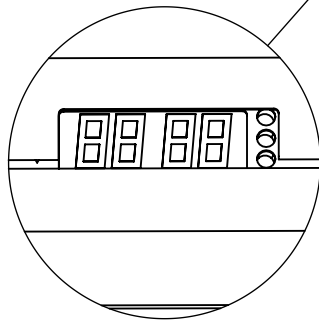

NOTE: ON/OFF SWITCH AND DIGITAL CONTROL ARE HIDDEN WHEN FACE FRAME IS IN PLACE.

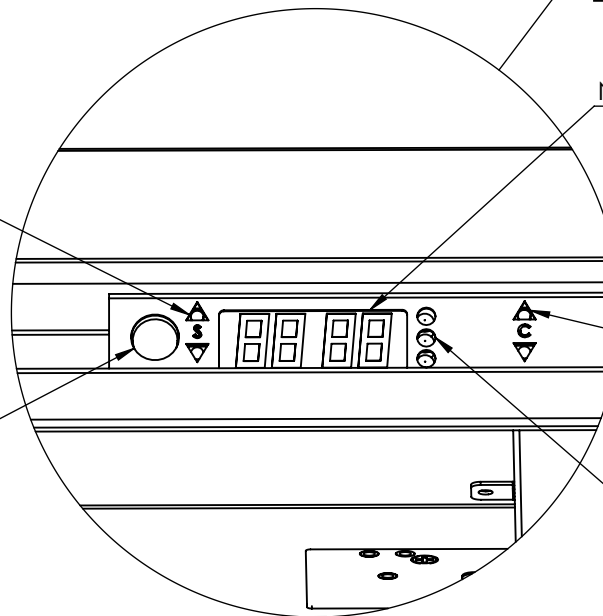

Setpoint Control

START/STOP Button

Numeric Display

Calibration Control

Status LED Indicators  
 - YELLOW -- Unit Off  
 - GREEN -- Unit Running  
 - RED -- Filter Dirty (Optional)

**FFDXRA SHOWN**



DRAWN BRS	MATERIAL	JOB NAME	TAG	QTY	REV # E
CHKD	FINISH	ENGINEER	DRAWING NAME INSTALL AND OPERATION		SHT 12/28
APRVD	SIZE	CONTRACTOR			SCL 1:15
					DO NOT SCALE

# FFDXRA & FFDXRA-MC

## REVERSE FLOW FAN FILTER UNIT

### MOTOR & ELECTRONICS ACCESSIBLE

#### FUSE

Each fan filter is equipped with an 8 Amp resettable or 5 Amp cartridge fuse to protect the unit from electrical spikes. In the electrical box accessible behind the filter.

**NOTE:** Before servicing fuse, cut power to the unit at the disconnect. Turning off the main power switch will not disconnect power from the fuse.

The cartridge fuse can be removed by turning the fuse holder counterclockwise a 1/4-turn. Remove the fuse from the fuse holder and discard. Insert new fuse and replace fuse holder.

**NOTE:** 277VAC units have a 5 A cartridge fuse. Others have a 8 A resettable fuse.

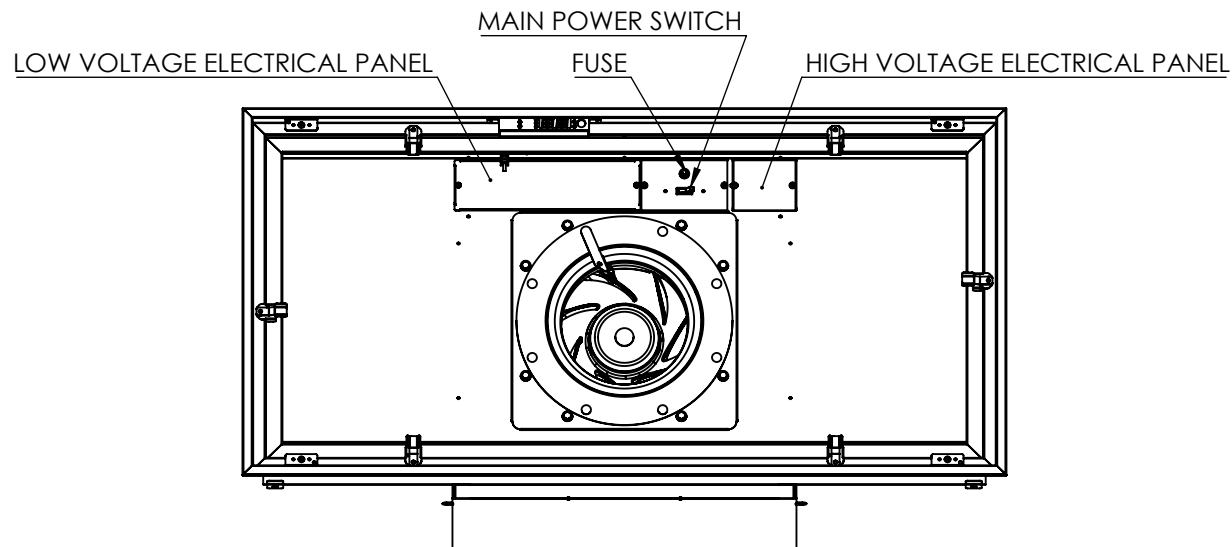

**FFDXRA SHOWN**



DRAWN BRS	MATERIAL	JOB NAME	TAG	QTY	REV # E
CHKD	FINISH	ENGINEER	DRAWING NAME INSTALL AND OPERATION		SHT 13/28
APRVD	SIZE	CONTRACTOR			SCL 1:12
					DO NOT SCALE

## CONTROLS

The fan filter unit can be controlled through various inputs:

1. Local potentiometer control
  - Adjust airflow from the face (disabled if unit external controlled)
  - Adjust flow from back of unit (disabled if face control present)
2. Individual unit wall mounted control (must be determined before ordering)
3. 0 - 10V/0 - 5V DC Control
4. 0 - 20mA/4 - 20mA Control
5. Full range of network controls including connection to BAS/BMS through MODBUS RTU RS485 control
  - BACNet IP, BACNet MS/TP, & LONWorks available with additional hardware

Additionally, monitoring and control of the FFU can be done through closed loop control from sensors such as pressure transducers, thermostats, partical counters, etc.

This manual will give basic information on how to connect controls and sensors to the unit. For more details refer to the instructions included with the controller or sensors.

## **SIGNAL BEHAVIOUR**

The Network CFM Setpoint is read and written directly in units of CFM.

External analog signals are scaled to a minimum and maximum airflow when in CFM control mode.  
IE: 0-5VDC 2.5VDC=0.5 of full range. = 0.5\*unit maximum CFM.

When operated from an external setpoint or network value 0-10% is reserved for local over-ride of the EC Mactor Control board POT so the unit can be adjusted from the main control board. 10%-20% is reserved for the remote Off Signal.

INP1/ANA1 Input		Control Function: % of Input Range		
Range	Units	ECM Control Pot 0-10%	Remote Off 10-20%	External Setpoint 20-100%
0-5	Volts	0 to 0.5	0.5 to 1.0	1.0 to 5.0
0-10	Volts	0 to 1.0	1.0 to 2.0	2.0 to 10.0
0-20	mA	0 to 2.0	2.0 to 4.0	2.0 to 20.0
4-20	mA	0 to 5.6	5.6 to 7.2	7.2 to 20.0

# FFDXRA & FFDXRA-MC

## REVERSE FLOW FAN FILTER UNIT MOTOR & ELECTRONICS ACCESSIBLE



DRAWN BRS	MATERIAL	JOB NAME	TAG	QTY	REV # E
CHKD	FINISH	ENGINEER	DRAWING NAME INSTALL AND OPERATION		SHT 14/28 SCL 1:10
APRVD	SIZE	CONTRACTOR	DO NOT SCALE		

# NETWORKING

# FFDXRA & FFDXRA-MC REVERSE FLOW FAN FILTER UNIT MOTOR & ELECTRONICS ACCESSIBLE

When networking the fan filter units either in a local area network (LAN) or connecting to a BAS/BMS system, each unit is connected in a "straight-through" daisy-chain using Cat5e or Cat6 network cables and the on-board RJ45 connectors.

If field cutting network cables, it is important for each end of the cable to be wired identically. However, assembled network cable are available; field assembled cables are the leading cause of problems in new systems.

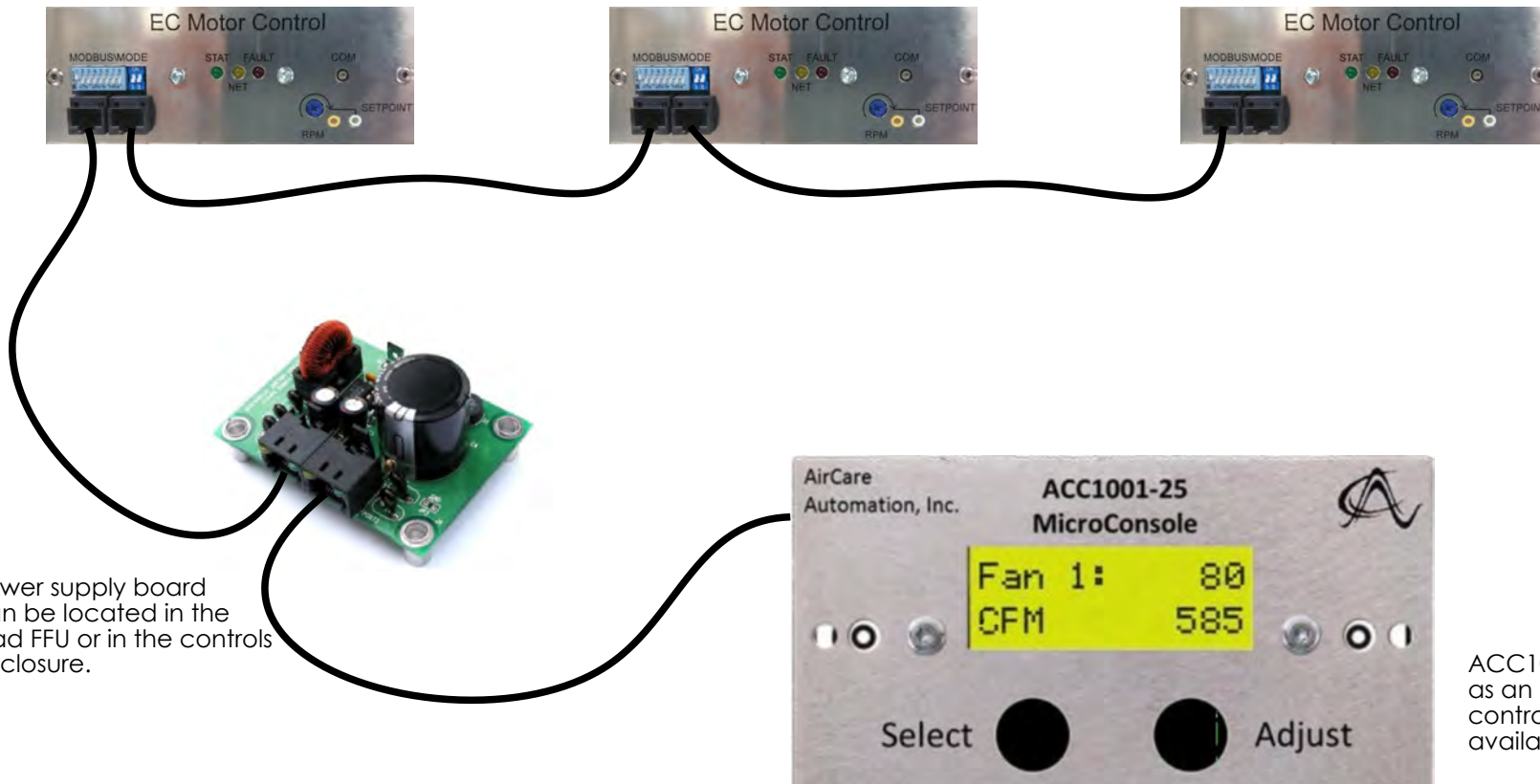

Power supply board can be located in the lead FFU or in the controls enclosure.

ACC1001 control used as an example. Other controller options available.



DRAWN BRS	MATERIAL	JOB NAME	TAG	QTY	REV # E
CHKD	FINISH	ENGINEER	DRAWING NAME INSTALL AND OPERATION		SHT 15/28
APRVD	SIZE	CONTRACTOR			SCL 1:10
					DO NOT SCALE

# FFDXRA & FFDXRA-MC

## REVERSE FLOW FAN FILTER UNIT

### MOTOR & ELECTRONICS ACCESSIBLE

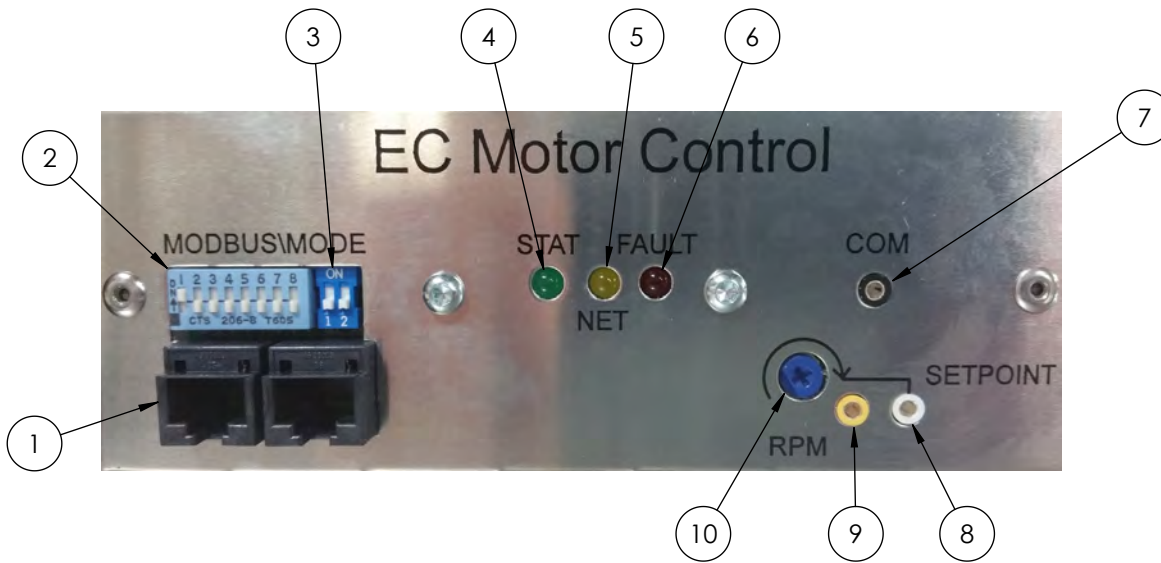

1. RJ45 Dual Jacks
2. Modbus Address DIP Switches
3. S1-1 and S1-2 Configuration DIP Switches
4. STATUS LED
5. NET LED (network activity)
6. FAULT LED
7. Multimeter Common
8. Multimeter Setpoint as mVDC
9. Multimeter CFM as mVDC
10. Onboard Setpoint Potentiometer

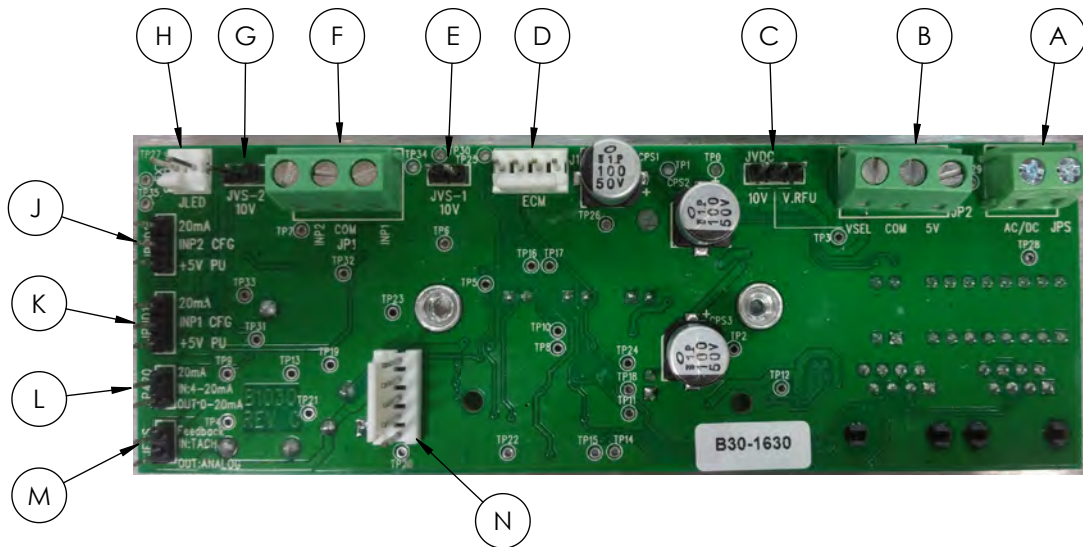

- A. JPS: Bias input power, isolated
- B. JP2: Accessory output voltages
- C. JVDC: Selector for 10V regulated or unregulated rectified and filtered bus voltage
- D. J1: EC Motor Port
- E. JVS-1: INP1 10V signal range selector
- F. JP1: INP1 and INP2 analog/digital inputs
- G. JVS-2: INP2 10V signal range selector
- H. JLED: External FAULT output
- J. JPUD2: INP2 digital input pull-up or 20mA signal format selector
- K. JPUD1: INP1 digital input pull-up or 20mA signal format selector
- L. JP420: 0-20mA or 4-20mA signal format selector
- M. JFBS: TACH or Analog 2 feedback signal selector
- N. Aux Board Port



DRAWN BRS	MATERIAL	JOB NAME	TAG	QTY	REV # E
CHKD	FINISH	ENGINEER	DRAWING NAME INSTALL AND OPERATION		SHT 16/28
APRVD	SIZE	CONTRACTOR			SCL 1:10
					DO NOT SCALE



# NETWORKING

# FFDXRA & FFDXRA-MC

## REVERSE FLOW FAN FILTER UNIT

### MOTOR & ELECTRONICS ACCESSIBLE

### DIP SWITCH SETTINGS

Each fan filter unit in a network must be set to a unique address between 1 and 247. Addresses 248- 255 are declared reserved per MODBUS protocol. A DIP switch block of eight switches are used for addressing. The control board supports Modbus Broadcast Address Zero for single and multiple register write commands (Modbus Function Codes 6 and 16).

Address settings are checked by the board controller only at power-up, so power must be cycled before any changes take effect.

Analog input setpoint modes preserve the ability to monitor and modify register values using a suitable controller console or PLC.

Therefore, addressing may be relevant for configuration, monitoring and/or troubleshooting even when units are intended to be used with analog setpoint input.

### Address Selection

When adjusted to the ON position, each DIP switch pole represents a value as follows:

DIP Switch Pole	Value
1	1
2	2
3	4
4	8
5	16
6	32
7	64
8	128

Calculate the address value of existing switch settings by adding the values of each DIP switch pole in the ON position, per the table at left.

Construct switch settings for a desired address value by successively subtracting the largest pole value that is less than the desired address value, repeating with each remainder until the remainder is zero. An example is provided below.

Example: Desired address is 114

$114 - 64 = 50$  SW1-7 ON  
 $50 - 32 = 18$  SW1-6 ON  
 $18 - 16 = 2$  SW1-5 ON  
 $2 - 2 = 0$  SW1-2 ON

$64+32+16+2 = 114$

\*See page 23 for more examples



1

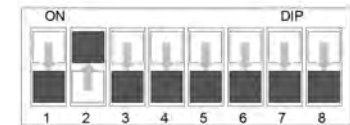

2



3

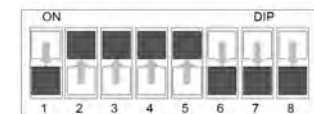

30



DRAWN BRS	MATERIAL	JOB NAME	TAG	QTY	REV # E
CHKD	FINISH	ENGINEER	DRAWING NAME INSTALL AND OPERATION		SHT 17/28
APRVD	SIZE	CONTRACTOR			SCL 1:10
					DO NOT SCALE

**CONFIGURATION DIP SWITCHES S1-1 & S1-2**

# FFDXRA & FFDXRA-MC

REVERSE FLOW FAN FILTER UNIT  
MOTOR & ELECTRONICS ACCESSIBLE

Switch	S1-1	S1-2
	Control Loop Mode	Setpoint Source
OFF	Open-Loop Control	Analog Setpoint
ON	Closed-Loop Control	Network Setpoint

Open-Loop -- Fan filter unit is controlled by a controller, i.e. on-board potentiometer or network controller.

Closed-Loop -- A sensor is used to maintain airflow, i.e. room pressure, roomtemp, or a particle counter.

Analog Setpoint -- Unit is controlled with an analog controller, i.e. on-board potentiometer or individual wall mounted controller (must be determined before ordering)

Network Setpoint -- Unit is controlled with a networked controller, i.e. ACC1 or ACM7052 touchscreen controller

**SENSOR SHUNT TABLES**

Shunt	JP420	JFBS	JVS-1*	JVS-2*
OUT	0 - 20mA	ANALOG	0 - 5VDC	0 - 5VDC
IN	4 - 20mA	N/A	0 - 10VDC	0 - 10VDC

\*Leave shunt out if using a 0-20mA or 4-20mA sensor.

**NOTES:**

- JP1 is for signal input
- JP2 is for output power
  - connect COM/5V --> 5V power supplied
  - connect COM/VSEL with 10V shunt --> 10V power supplied
  - connect COM/VSEL with V.RFU shunt --> Full wave rectified power supplied (~33VDC)
- INP1 on JP1 wiring block is for monitoring only
  - 0 - 10VDC
  - 0 - 5VDC
  - 0 - 20mA
  - 4 - 20mA
- INP2 on JP1 wiring block is for closed-loop feedback monitoring
  - Controlling airflow by room pressure or particle counter

**Shunt Table for JP1 wiring block**

Center Pin to...	JPUD1:INP1	JPUD2:INP2
No connection	ANALOG 5V or 10V	ANALOG 5V or 10V
20mA	ANALOG 20mA	ANALOG 20mA
+5V PU	DIGITAL 10kΩ pull-up TO 5V	DIGITAL 10kΩ pull-up TO 5V

**Shunt Table for JP2 wiring block**

Center Pin to...	JVDC
No Connection	VSEL = no connection; open
10V	VSEL = 10V regulated
V.RFU	VSEL = DC filtered, unregulated, ~33VDC



DRAWN BRS	MATERIAL	JOB NAME	TAG	QTY	REV # E
CHKD	FINISH	ENGINEER	DRAWING NAME INSTALL AND OPERATION		SHT 18/28
APRVD	SIZE	CONTRACTOR			SCL 1:10
					DO NOT SCALE

# AIRFLOW SENSOR WIRING

# FFDXRA & FFDXRA-MC

REVERSE FLOW FAN FILTER UNIT  
MOTOR & ELECTRONICS ACCESSIBLE

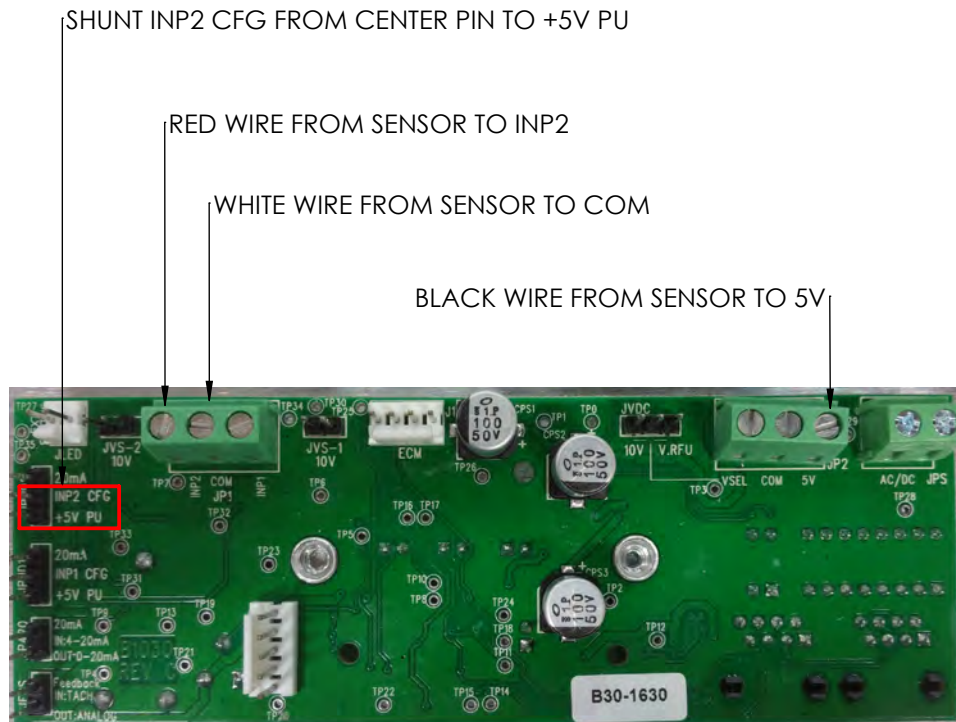

Switch	S1-1	S1-2
		<b>Control Loop Mode</b>
<b>OFF</b>	Open-Loop Control	Analog Setpoint
<b>ON</b>	Closed-Loop Control	Network Setpoint



DRAWN BRS	MATERIAL	JOB NAME	TAG	QTY	REV # E
CHKD	FINISH	ENGINEER	DRAWING NAME INSTALL AND OPERATION		SHT 19/28 SCL 1:10
APRVD	SIZE	CONTRACTOR			DO NOT SCALE

# WIRING A REMOTE MOUNTED POT TO CONTROL BOARD

**FFDXRA & FFDXRA-MC**  
 REVERSE FLOW FAN FILTER UNIT  
 MOTOR & ELECTRONICS ACCESSIBLE

## Wiring of Pot

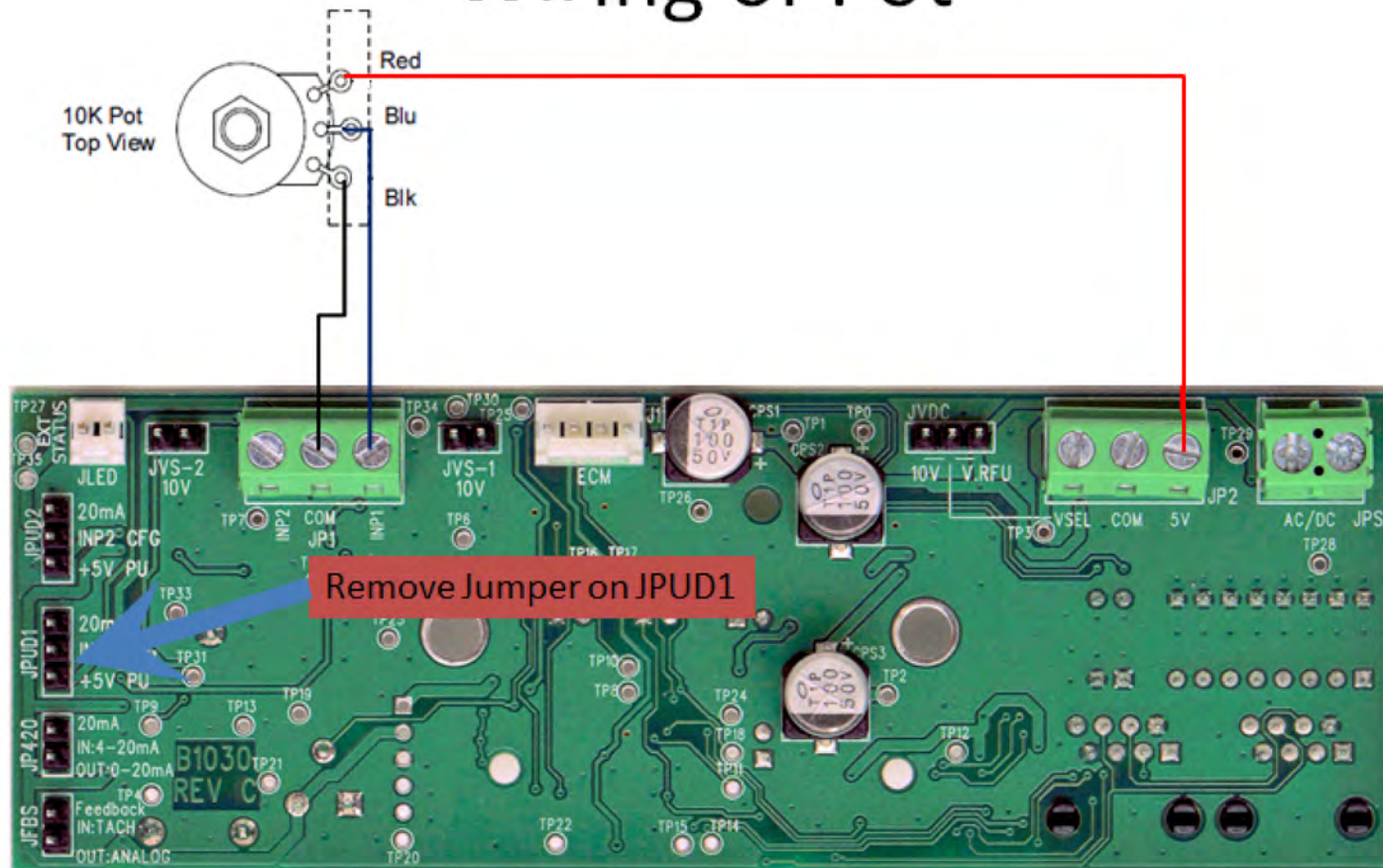

DRAWN BRS	MATERIAL	JOB NAME	TAG	QTY	REV # E
CHKD	FINISH	ENGINEER	DRAWING NAME INSTALL AND OPERATION		SHT 20/28
APRVD	SIZE	CONTRACTOR			SCL 1:10
					DO NOT SCALE

# WIRING OF 0 -10 VDC INPUT SIGNAL TO CONTROL FAN SPEED

# FFDXRA & FFDXRA-MC

REVERSE FLOW FAN FILTER UNIT  
MOTOR & ELECTRONICS ACCESSIBLE

Switch	S1-1	S1-2
	Control Loop Mode	Setpoint Source
OFF	Open-Loop Control	Analog Setpoint
ON	Closed-Loop Control	Network Setpoint

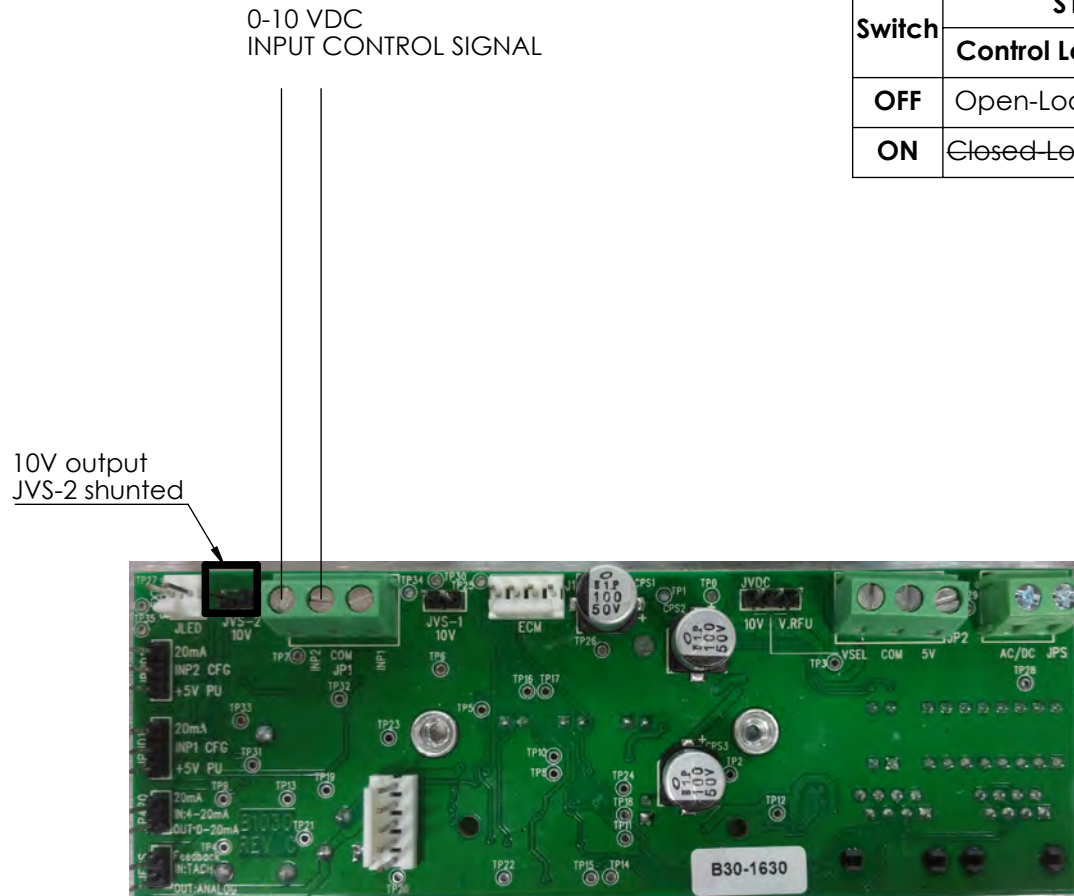

DRAWN BRS	MATERIAL	JOB NAME	TAG	QTY	REV # E
CHKD	FINISH	ENGINEER	DRAWING NAME INSTALL AND OPERATION		SHT 21/28 SCL 1:10
APRVD	SIZE	CONTRACTOR			DO NOT SCALE

# EXAMPLE OF WIRING A PRESSURE TRANSDUCER TO CONTROL BOARD FOR FEEDBACK OR MONITORING THROUGH CONTROLLER

## FFDXRA & FFDXRA-MC REVERSE FLOW FAN FILTER UNIT MOTOR & ELECTRONICS ACCESSIBLE

- Pressure transducer provides 0-10VDC output signal
- Powered by ~33VDC supply

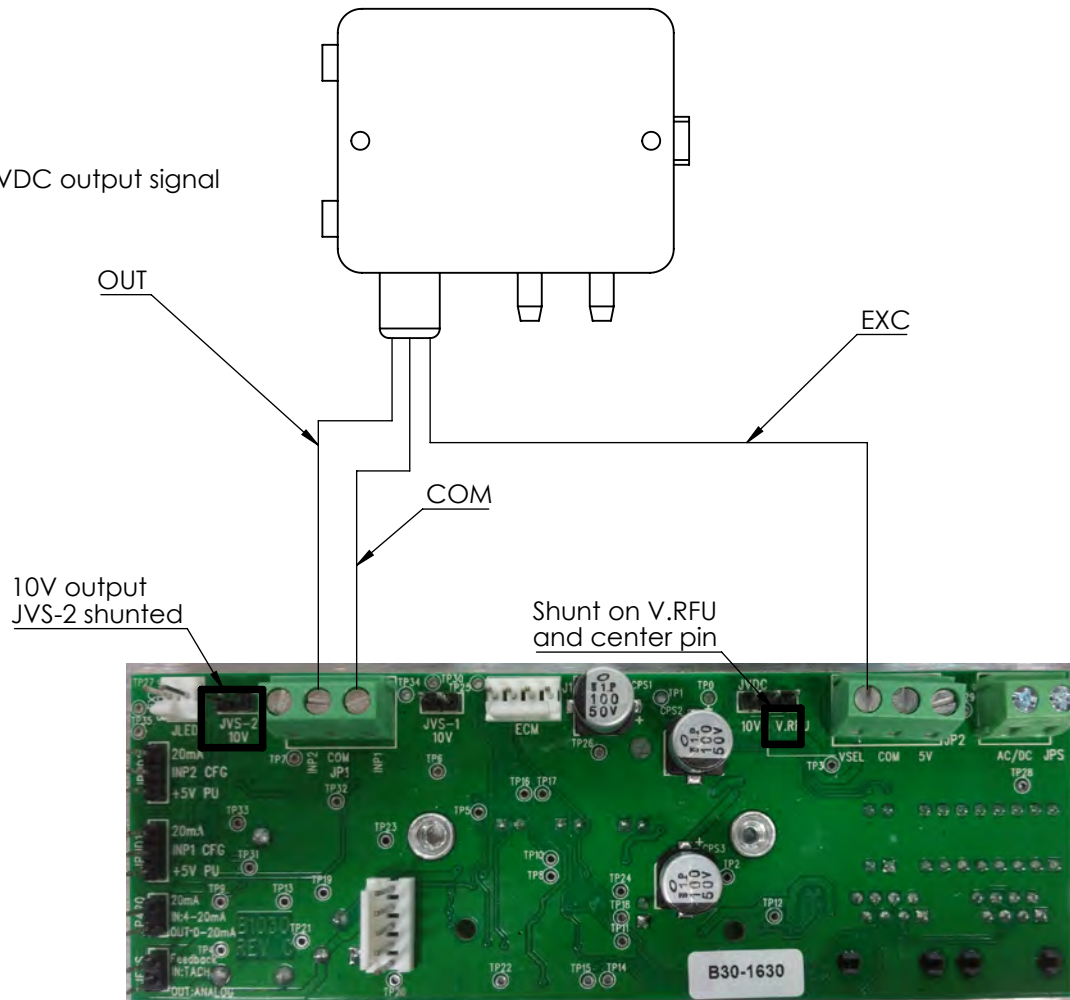

DRAWN BRS	MATERIAL	JOB NAME	TAG	QTY	REV # E
CHKD	FINISH	ENGINEER	DRAWING NAME INSTALL AND OPERATION		SHT 22/28
APRVD	SIZE	CONTRACTOR			SCL 1:10
					DO NOT SCALE

# EXAMPLE OF WIRING A SENSOR TO CONTROL BOARD FOR FEEDBACK OR MONITORING THROUGH CONTROLLER

# FFDXRA & FFDXRA-MC REVERSE FLOW FAN FILTER UNIT MOTOR & ELECTRONICS ACCESSIBLE

- Pressure transducer provides 4-20mA output signal
- Powered by ~33VDC supply

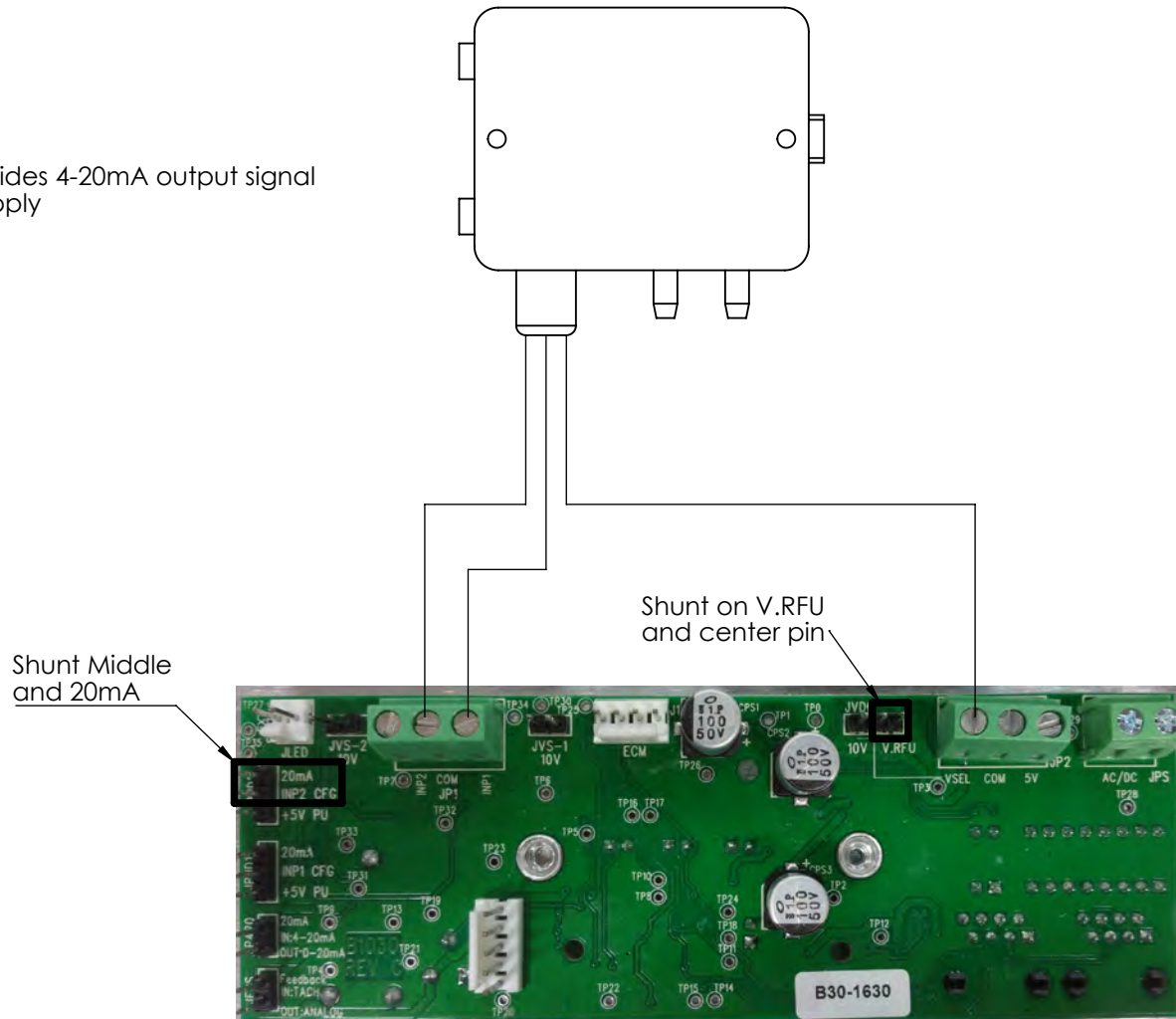

DRAWN BRS	MATERIAL	JOB NAME	TAG	QTY	REV # E
CHKD	FINISH	ENGINEER	DRAWING NAME INSTALL AND OPERATION		SHT 23/28
APRVD	SIZE	CONTRACTOR			SCL 1:10
					DO NOT SCALE

# FFDXRA & FFDXRA-MC

## REVERSE FLOW FAN FILTER UNIT

### MOTOR & ELECTRONICS ACCESSIBLE

### Testing

Each fan filter unit is thoroughly tested at the factory before shipment. However, many codes and standards require testing for bypass leakage after installation. The manufacturer encourages that the customer contact an independent, certified testing organization with technicians that are trained and experienced in performance, evaluation, and maintenance of clean air equipment.

The manufacturer recommends at least 30 minutes elapse after HEPA/ULPA filter installation before performing any type of challenge leak testing. The unit should be sealed to the ceiling and the room should have a negative pressure held during testing and normal operation.

### Trouble Shooting

#### Low Airflow

- If optional red HEPA-lert LED light is on, replace the HEPA filter.
- Inspect the pre-filter. Clean or replace as necessary.
- Adjust the digital speed control for higher airflow output.
- Check the power supply for proper voltage, amperage, and distribution frequency
- Verify dip switches are correct for type of controls used.
- Replace HEPA filter if airflow remains low.

#### High Airflow

- Adjust digital speed control for lower output.
- Verify dip switches are correct for type of controls used.

#### Excessive Contamination

- Insure that upstream airstream is clear of large obstructions.
- Check airflow and if not desired airflow see above.
- Conduct smoke or photometer test on HEPA filter and gel seal. Seal or replace the HEPA filter as necessary.



DRAWN BRS	MATERIAL	JOB NAME	TAG	QTY	REV # E
CHKD	FINISH	ENGINEER	DRAWING NAME INSTALL AND OPERATION		SHT 24/28
APRVD	SIZE	CONTRACTOR			SCL 1:10
					DO NOT SCALE



# FFDXRA & FFDXRA-MC

REVERSE FLOW FAN FILTER UNIT  
MOTOR & ELECTRONICS ACCESSIBLE

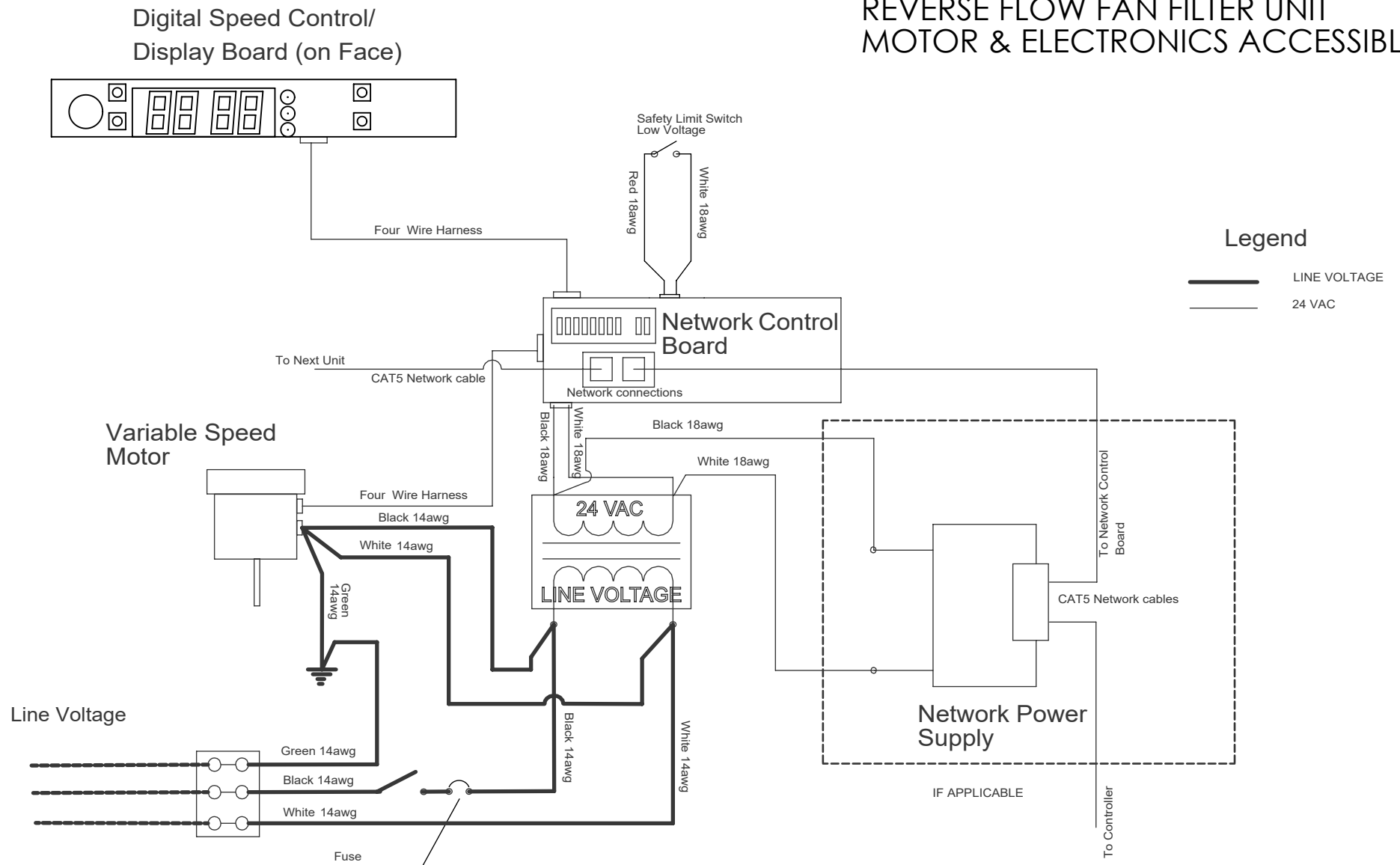

DRAWN BRS	MATERIAL	JOB NAME	TAG	QTY	REV # E
CHKD	FINISH	ENGINEER	DRAWING NAME INSTALL AND OPERATION		SHT 25/28
APRVD	SIZE	CONTRACTOR			SCL 1:1.2
					DO NOT SCALE

### MOTOR TERMINALS

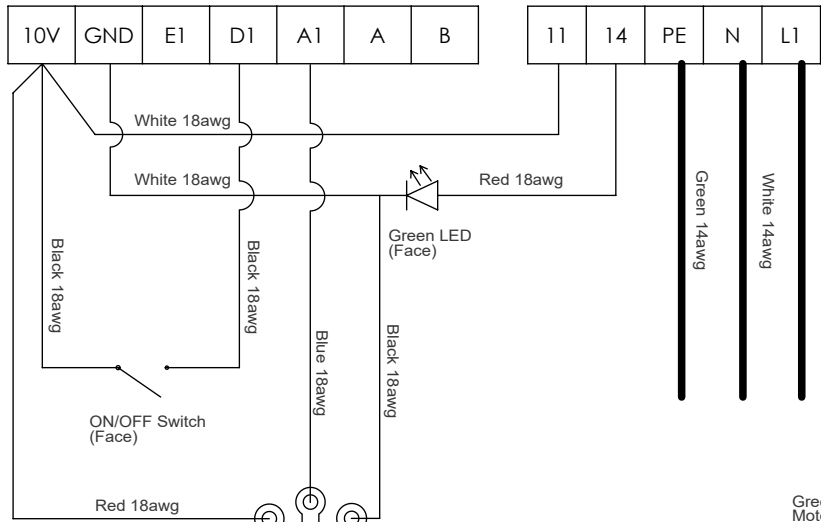

# FFDXRA & FFDXRA-MC

REVERSE FLOW FAN FILTER UNIT  
MOTOR & ELECTRONICS ACCESSIBLE

ID	FUNCTION
10V	10VCD SUPPLY
GND	SIGNAL GROUND
E1	TACHOMETER OUTPUT, PWM
D1	MOTOR START
A1	SPEED INPUT 0-10V
A	MODBUS DATA+
B	MODBUS DATA-
11	MOTOR STATUS RELAY
14	MOTOR STATUS RELAY
PE	EARTH GROUND
N	NEUTRAL
L1	LINE POWER

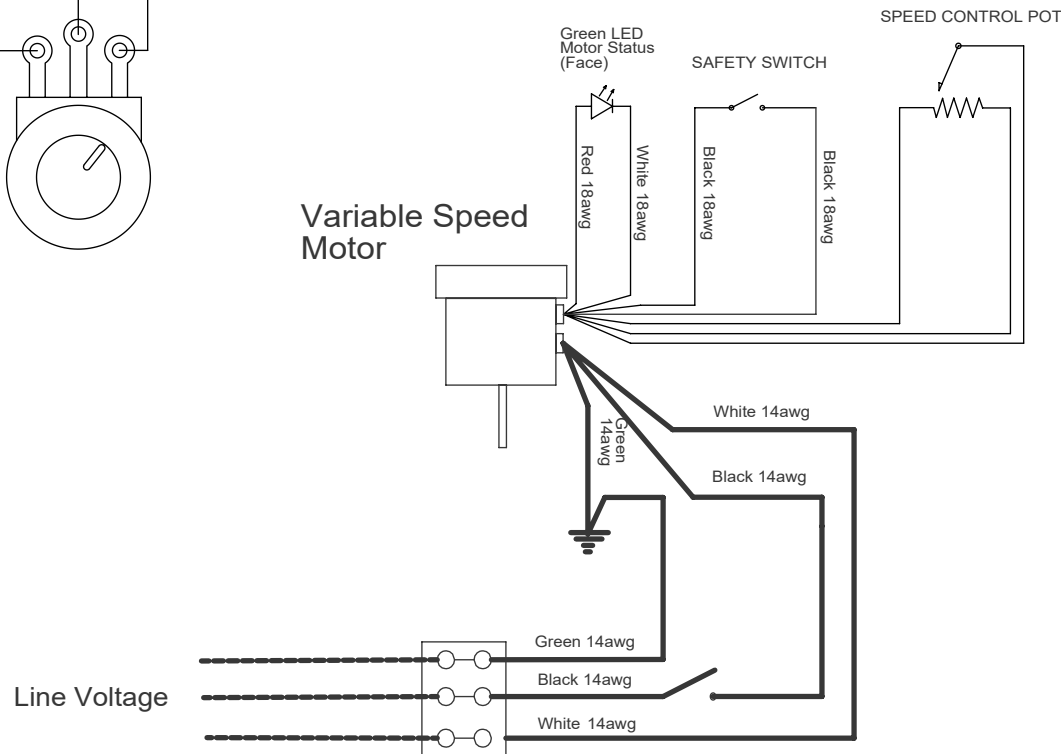

### Legend



DRAWN BRS	MATERIAL	JOB NAME	TAG	QTY	REV # E
CHKD	FINISH	ENGINEER	DRAWING NAME INSTALL AND OPERATION		SHT 26/28 SCL 1:1.2
APRVD	SIZE	CONTRACTOR	DO NOT SCALE		

# FFDXRA & FFDXRA-MC

## REVERSE FLOW FAN FILTER UNIT

### MOTOR & ELECTRONICS ACCESSIBLE

	10		20		30
	9		19		29
	8		18		28
	7		17		27
	6		16		26
	5		15		25
	4		14		24
	3		13		23
	2		12		22
	1		11		21

#### DIP SWITCH SETTINGS FOR UP TO 30 FAN FILTER UNITS FOR MORE UNITS SEE BELOW.

Calculate the address value of existing switch settings by adding the values of each DIP switch pole in the ON position, per the table below. Construct switch settings for a desired address value by successively subtracting the largest pole value that is less than the desired address value, repeating with each remainder until the remainder is zero. An example is provided below.

DIP Switch Pole	Value
1	1
2	2
3	4
4	8
5	16
6	32
7	64
8	128

Example: Desired address is 114

114 - 64 = 50 SW1-7 ON  
 50 - 32 = 18 SW1-6 ON  
 18 - 16 = 2 SW1-5 ON  
 2 - 2 = 0 SW1-2 ON

64+32+16+2 = 114



DRAWN BRS	MATERIAL	JOB NAME	TAG	QTY	REV # E
CHKD	FINISH	ENGINEER	DRAWING NAME INSTALL AND OPERATION		SHT 27/28
APRVD	SIZE	CONTRACTOR			SCL 1:10
					DO NOT SCALE